

醒发箱 RETARDER PROOFER CABINET

产品特点 General Features

- 双系统上下独立运行，可实现不同场景的应用
- 触摸屏操作面板，各工序运行状态清晰，基本功能可通过触摸屏简单实现
- 具有加温、加湿、冷藏、冷冻等功能
- 可预设工作时间、工序，自动进行温度、湿度、冷藏、冷冻等控制直至最终发酵
- 可放标准400×600烤盆
- 层架间距可调
- 自动回弹门铰
- The dual system runs independently up and down, enabling applications in different scenarios
- Touch screen operation panel, with clear operation status of each process, and basic functions can be easily implemented through touch screen
- It has functions such as heating, humidification, refrigeration, freezing, etc
- It can preset working hours and processes, automatically control temperature, humidity, refrigeration, freezing, etc. until the final fermentation
- Can hold a standard 400×600 baking basin
- Adjustable shelf spacing
- Automatic spring door hinge

产品细节 Product Details



- | | |
|---------------|---|
| 1. 双系统触摸屏操作面板 | 1. Dual system touch screen operation panel |
| 2. 电源开关 | 2. Power switch |
| 3. 内箱配有LED灯管 | 3. The inner box is equipped with LED tubes |
| 4. 门把手 | 4. Door handle |
| 5. 不锈钢层架 | 5. Stainless steel shelf |
| 6. 万向脚轮 | 6. Universal caster |

产品参数 Technical Data

型号 Model	DF36
产品尺寸 Product size (mm)	900 × 1125 × 2075
冷媒类型 Refrigerant	R404a
温度范围 Temperature (°C)	-20 ~ +40
湿度范围 Humidity (%)	40 ~ 90
净重 Net weight (Kg)	261
容积 Net capacity (L)	475 × 2
额定功率 Rated power (W)	2600

产品认证 Product Certification



* 我司有权利更改产品设计和配置，不会提前告知客户！ We have the right to change the product design and configuration without informing customers in advance!



简单易懂的电脑控制面板能设置程序，可为面包提供最佳发酵环境，全自动智能工作无需人工看守，轻松完成。
The simple and easy to understand computer control panel can set programs to provide the most suitable fermentation environment for bread. The fully automatic intelligent work does not require manual supervision and can be easily completed.

平面图
Plan View

正视图 Front View

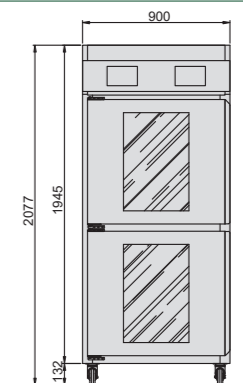

侧视图 Side View

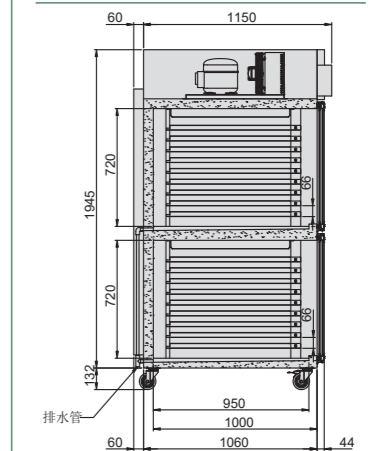

侧视图 Side View

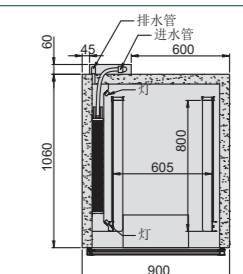

黑色不锈钢
Black stainless steel color



原色不锈钢
Stainless steel color